

ESPACE CLAIR ROOF FINISHES

TECHNICAL CHARACTERISTICS



	PANEL	FASCIA BOARD
Wall thickness	1 to 9 mm	9,19 mm
Overlap	200 - 250 - 300 - 350 mm	150 - 180 - 200 - 225 - 250 - 300 or 410 mm
Thickness	9 to 10 mm	9 to 19 mm
Material	cellular pvc and expanded pvc	expanded pvc
Aspect	elegy,moulded or ribbed	smooth

«F» FASCIA BOARD

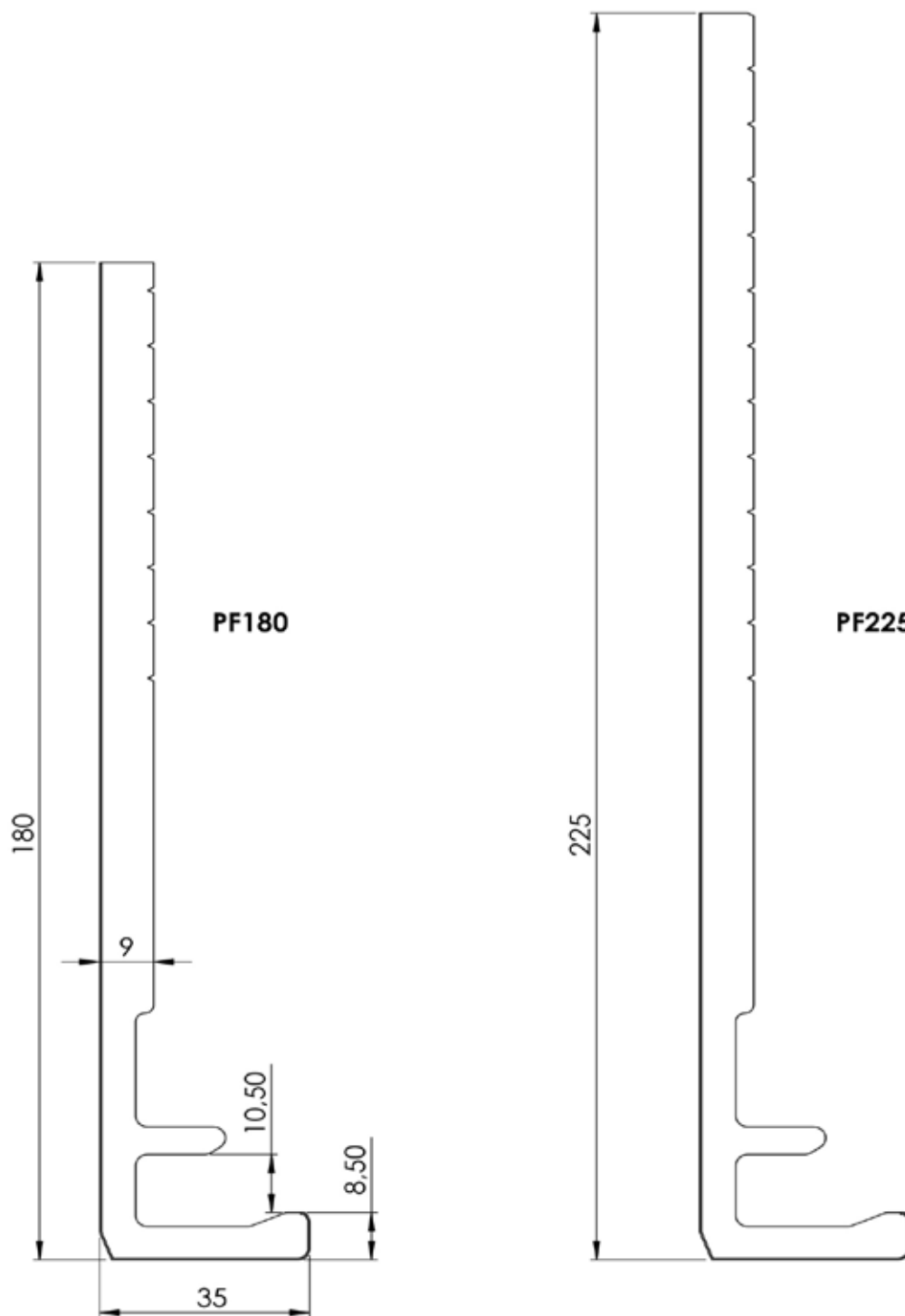

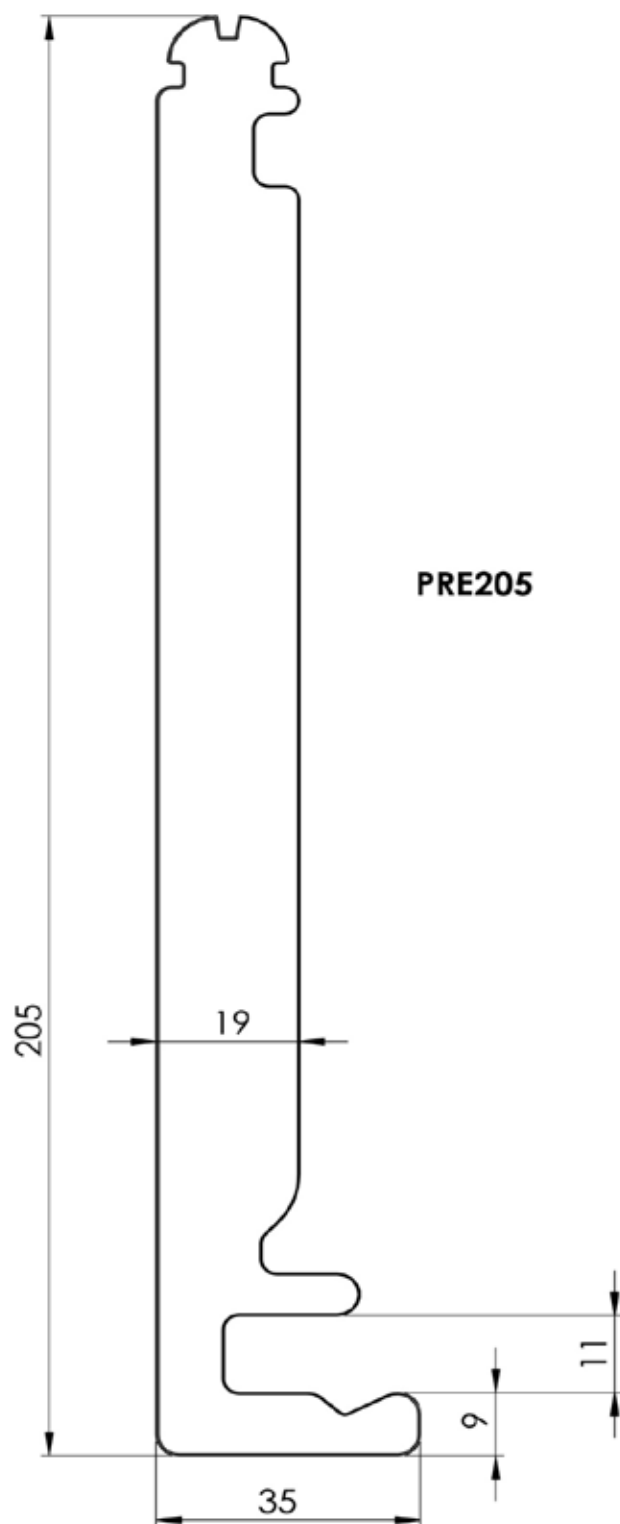
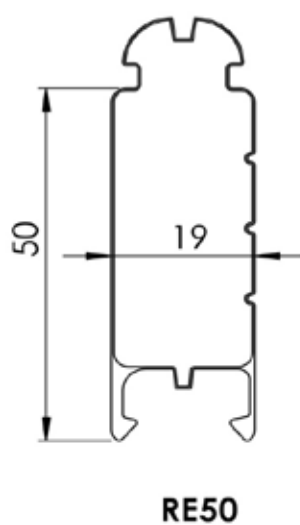

«L» FASCIA BOARD

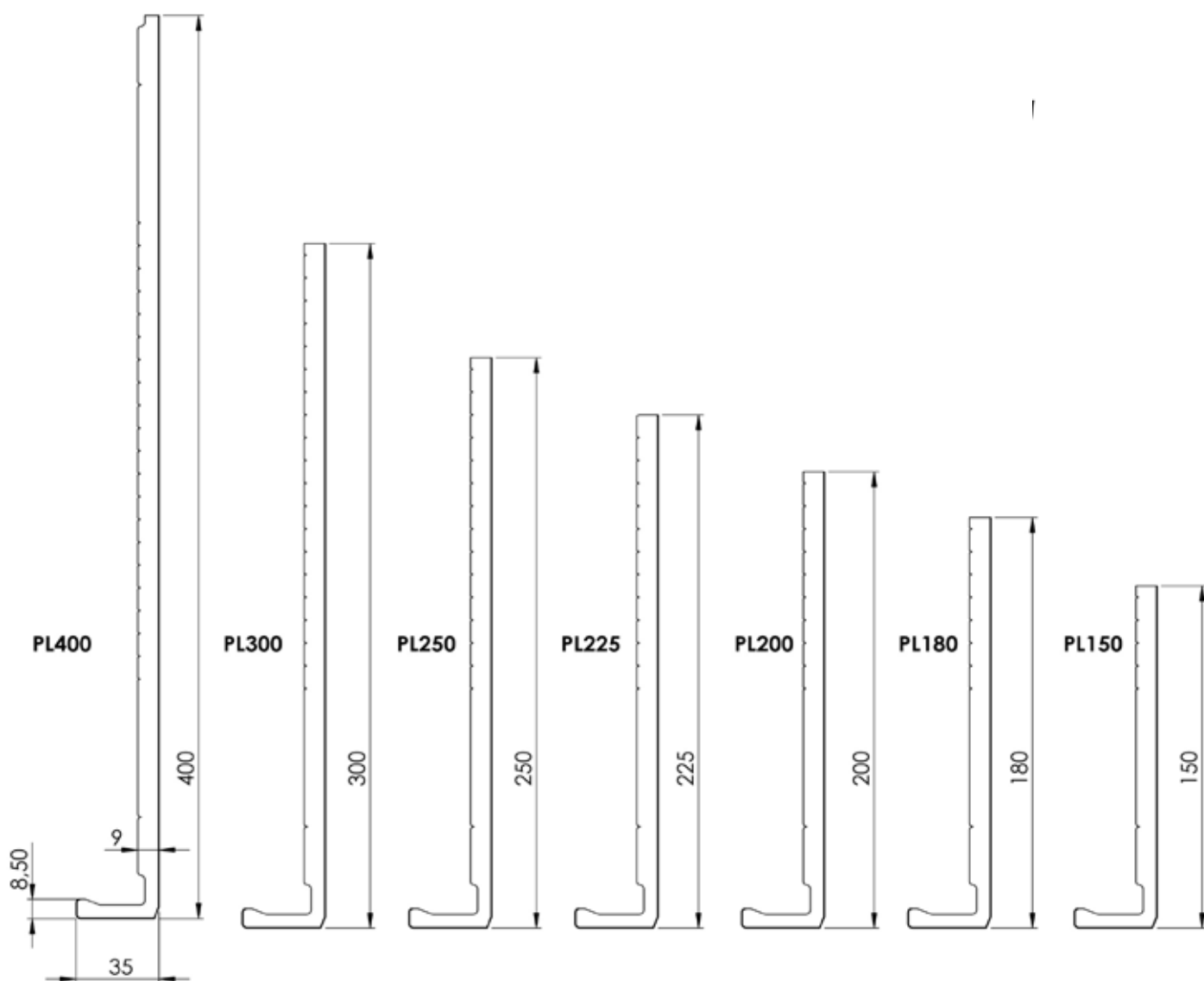

LARGE FASCIA BOARD

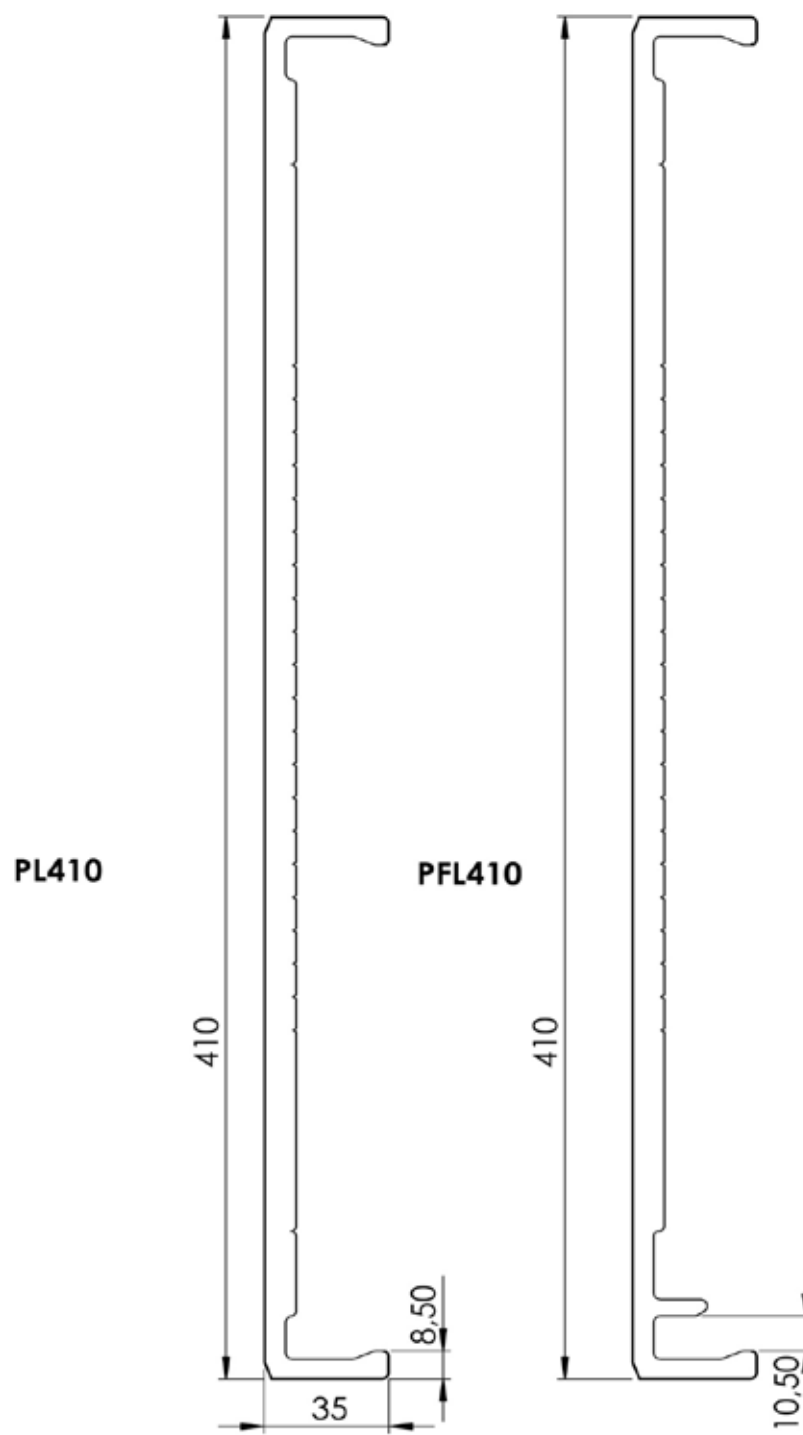

UNDER-EAVE PANELS

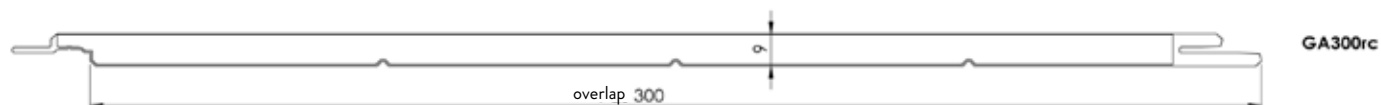
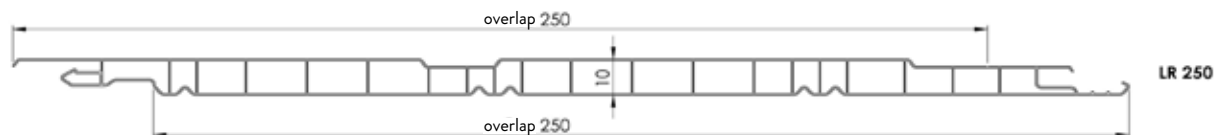

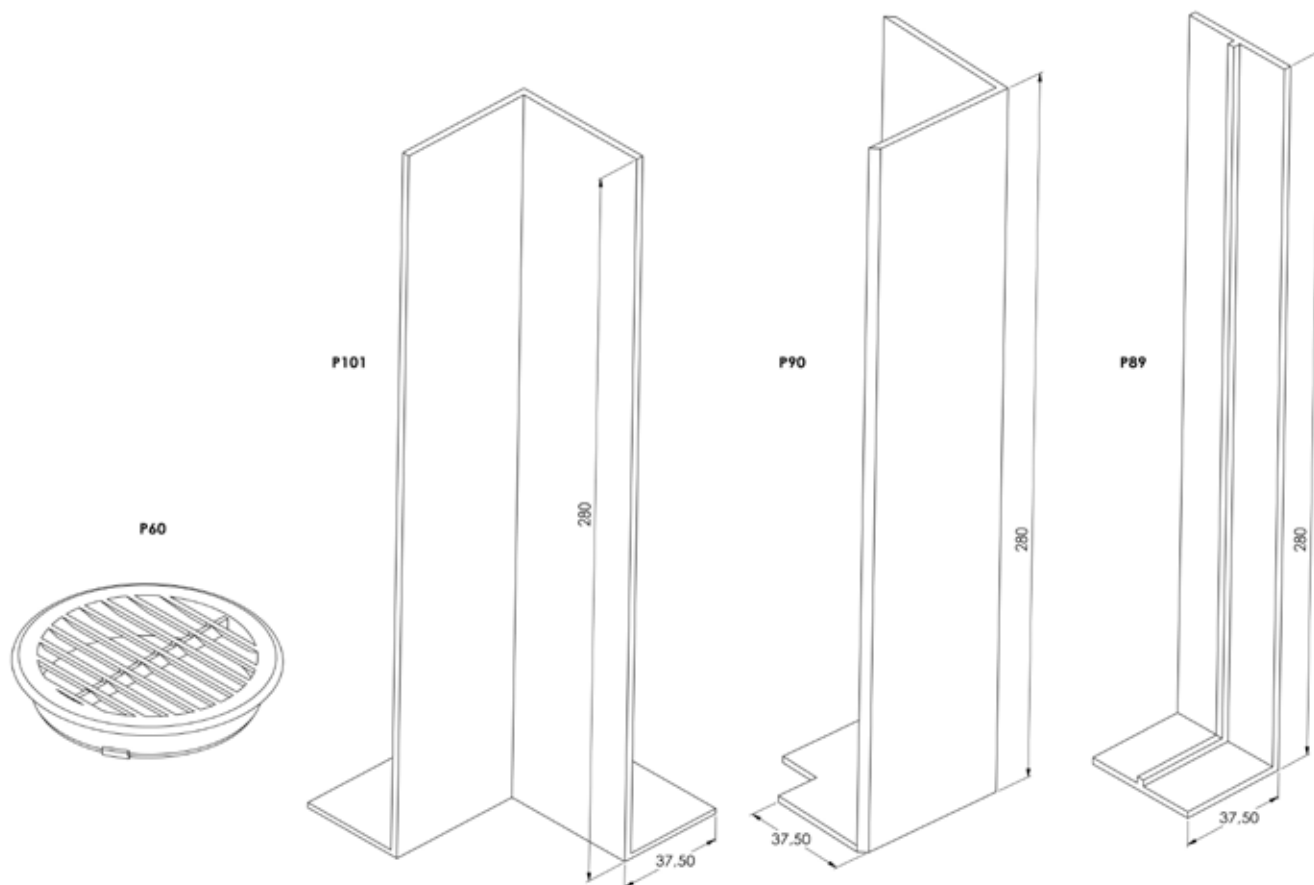

COMPLEMENTARY PROFILES

