

ALPHACAN
INNOVATIVE PROFILES & SOLUTIONS

A MEMBER OF

ALPHAPRO



GENERAL CATALOGUE
PVC WINDOWS PROFILES
AUTHOR'S COMPONENTS



ENGLISH



PVC PROFILES FOR PREMIUM
DOORS AND WINDOWS

EXCLUSIVITY, INNOVATION, DESIGN

HEADQUARTER SABLÉ-SUR-SARTHE

Z.I. de l'Aubrée
72300 Sablé-sur-Sarthe
FRANCE
+33 (0) 2 43 62 48 48

CLERVAL

Rue de Santoche
25340 Pays-de-Clerval
FRANCE
+33 (0) 3 81 99 18 18

GAILLAC

Chemin de Piquerouge
81600 Gaillac
FRANCE
+33 (0) 5 63 81 12 00

CHANTONNAY

52 avenue Monseigneur Batiot
85110 Chantonay
FRANCE
+33 (0) 2 51 48 50 50

ARCO

Via S.Sisto, 24
38062 Arco
ITALY
+ 39 0464 587 500

ZAGREB

Zagrebacka 93
10291 Prigorje Brdovecko
CROATIA
+385 1 33 40 666

Founded in 1969, ALPHACAN is part of ALPHAPRO, a group specialized in the production of U-PVC profiles for building applications (profiles for windows, doors, shutter systems, facade decorations) but also for tailor-made applications dedicated to different industrial fields.

A fundamental know-how, an international experience and a spirit of innovation allow ALPHACAN to be recognized as a key player in tomorrow's activities.

Supported by marketing and R&D professionals, the company is capable to adapt itself to the evolution of the markets and its clients, to offer concrete improvements and innovations thanks to the synergy with the activities of its partners.

ALPHAPRO owns 6 plants across Europe.



Thermal Insulation

PVC multi-chamber profiles have an extremely low thermal conductivity value, which results in a better thermal insulation and a significant economic saving.



Sound Insulation

Thanks to its sound-waves reduction capacity, PVC multi-chamber profiles assure optimal sound insulation values and guarantee the maximum level of comfort.



Water and air tightness and stability to weathering

Frame, sash and special gaskets ensure an excellent tightness against leaks, also under extreme weather conditions. In fact, profiles are Climate S certified, specific for severe climates.



Fire resistance

Extremely safe for any kind of building, PVC is self-extinguishing.



Design versatility

Our profiles, with their modern design, can be easily adapted to any architectural-environmental context: sea, mountain and urban environments. We offer optimal solutions for both new constructions and renovations.



Ecology and environment

PVC has the lowest water footprint if compared to other materials. About half of its initial composition is constituted by common salt and is fully recyclable, as well as production rejects are fully recycled.



Easy to install

Modern window renovation requires the installation of the frame without removing the older one and without intervening on the existing masonry.



PVC requires minimal maintenance

The action of time and weather, such as humidity, saltiness and solar irradiation, do not alter PVC, which only needs a normal cleaning over time.

ADVANTAGES OF PVC

PROFILES FOR WINDOWS AND DOORS
WITH HIGH ENERGY EFFICIENCY





WINDOWS AND DOORS



ALPHA EXTREME

- Modern design with squared geometries, a unique and distinctive feature with minimal profile sections which increases the glazed surface and improves the passage of light
- Excellent thermal and acoustic insulation performance: excellent values in quality certification tests
- Customisation and colours: the widest range of interior and exterior window decors with best match of base and gasket colours that fits every environment

SYSTEM	PROPERTIES	VALUE	STANDARD
ALPHA EXTREME	Transmittance (U_f) [$W/m^2 K$]	1,0	UNI EN ISO 10077-1
	Transmittance with ecoreinforcement (U_f) [$W/m^2 K$]	0,92	
	Air permeability	Class 4	UNI EN 12207
	Water tightness	U_p to E 1200	UNI EN 12208
	Wind load resistance	U_p to C5	UNI EN 12210
	Load bearing capacity 350 N	passed	UNI EN 14351-1
	Acoustics (R_w)	44 dB (with 46 dB glass)	UNI EN 10140-2

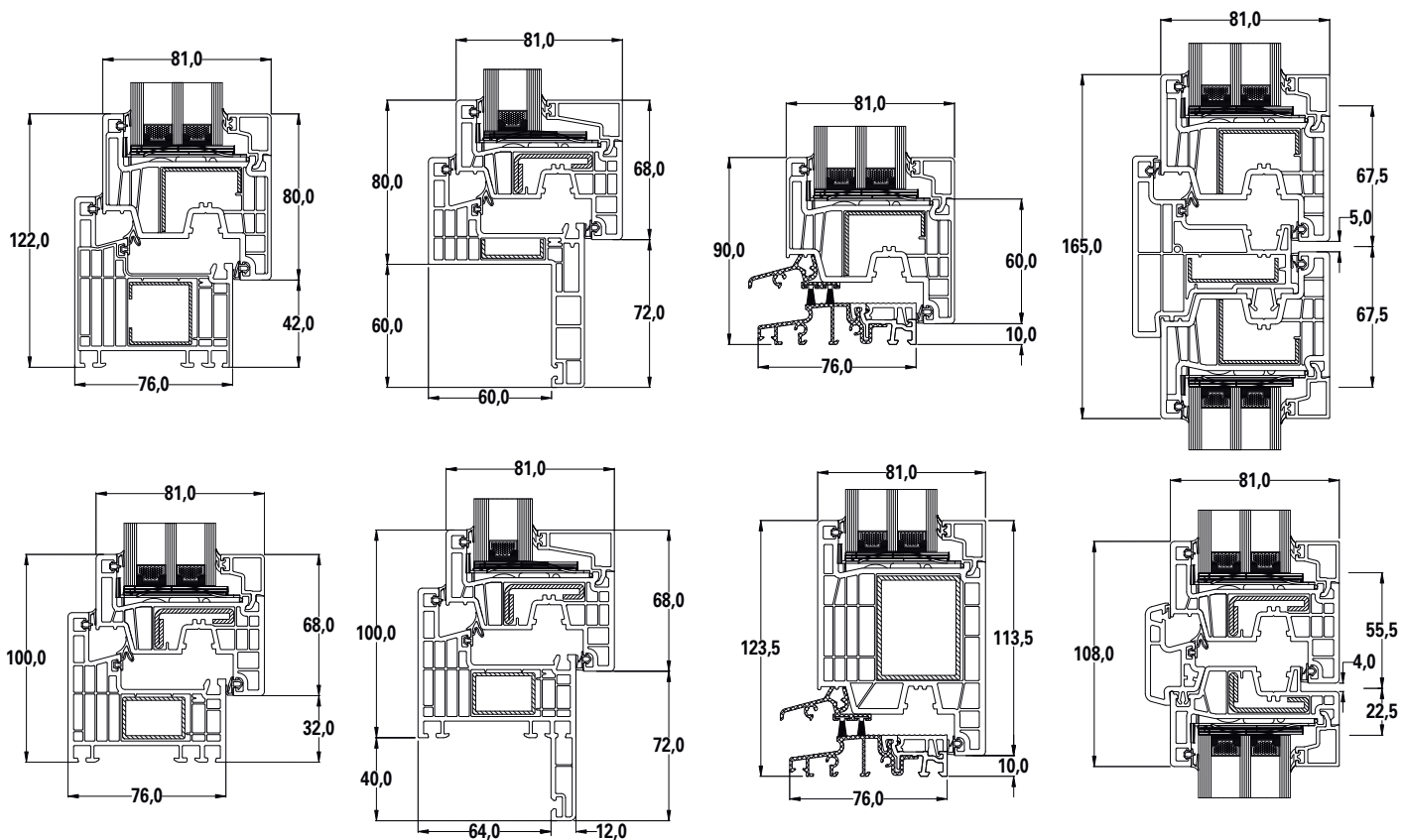

CONSTRUCTION PROPOSALS

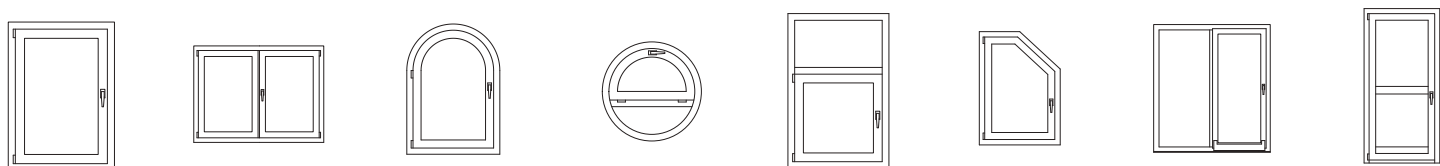



ALPHA EXTREME MODULAR

- Minimal and modular design: essential and squared geometries, a unique and distinctive feature with minimal profile sections that increases the glazed surface up to 30% more than a standard PVC window
- Innovative modular system which allows for a minimalist sash and a homogenous interior surface, without glazing beads
- Possibility to manage the sash inner side independently from the outer side. This makes it possible to create different sash types by combining different types of profiles
- High thermal insulation performance: excellent values in quality certification tests
- Customisation and colours: the widest range of finishes for the inside and outside of the window with base and gaskets that match in colour

SYSTEM	PROPERTIES	VALUE	STANDARD
ALPHA EXTREME MODULARE	Transmittance (U_f) [$W/m^2 K$]	1,0	UNI EN ISO 10077-1
	Transmittance with ecoreinforcement ($U_{f,e}$) [$W/m^2 K$]	0,94	
	Air Permeability	Class 4	UNI EN 12207
	Water tightness	U_p to 9A	UNI EN 12208
	Wind load resistance	U_p to C5	UNI EN 12210
	Load bearing capacity 350 N	passed	UNI EN 14351-1

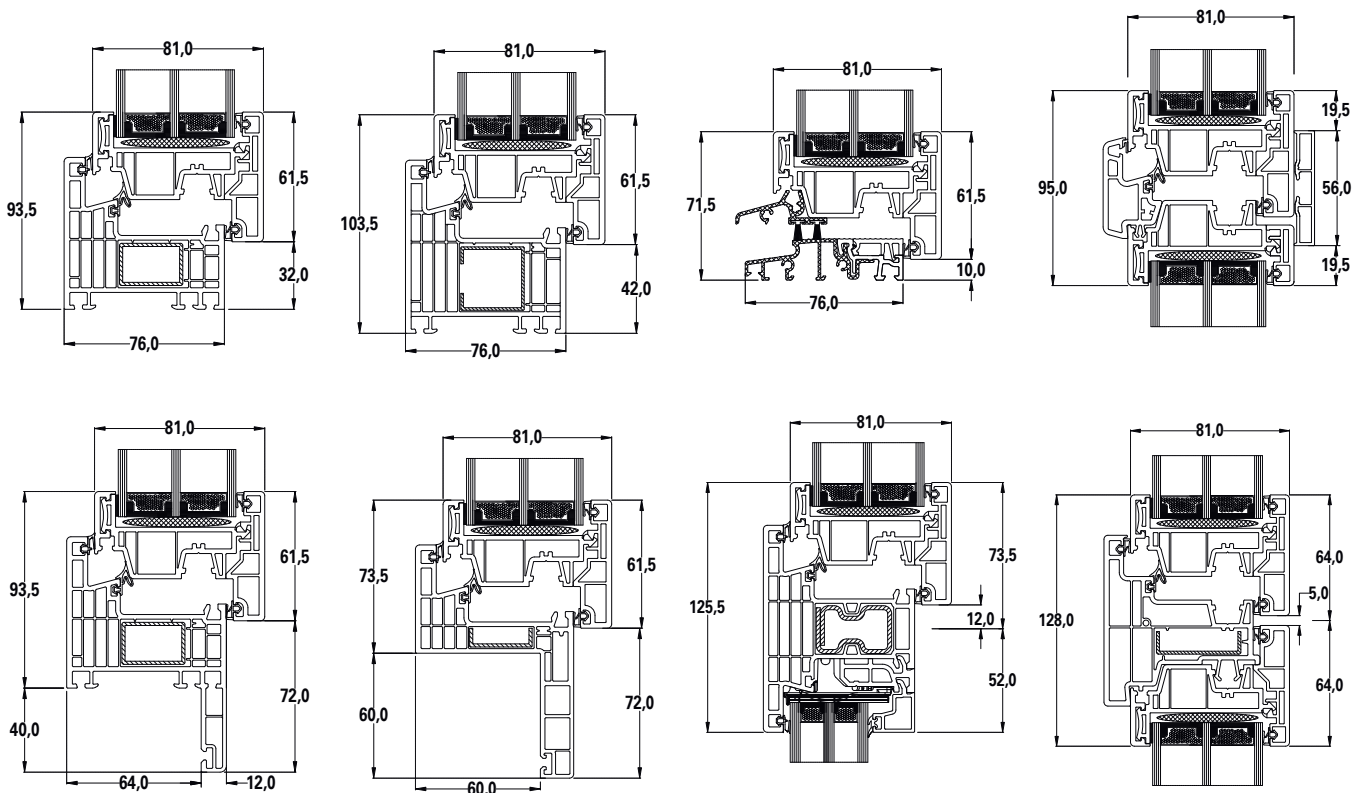

CONSTRUCTION PROPOSALS

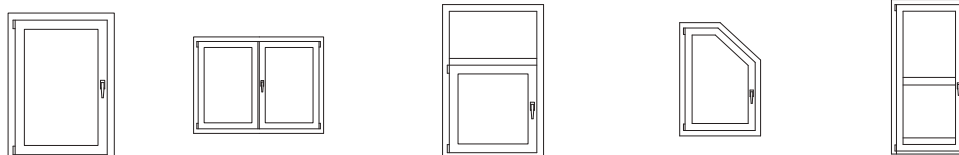



IN'ALPHA70

- Two-gasket system with depth up to 80 mm and 6 chambers
- Maximum attention to the detail: colour match between gasket and the profile surface
- Elegant minimal design which also ensures exceptional thermal performances up to $U_w = 0,9 \text{ W/m}^2 \text{ K}$
- Available in a wide range of colours and finishes

SYSTEM	PROPERTIES		VALUE		STANDARD
IN'ALPHA70	Transmittance (U_f) [W/m ² K]	Dimensions	Classic	Eco-reinforcement	UNI EN ISO 10077-2
		70/70	1,30	1,10	UNI EN 12412-2
		70/80	1,27	1,10	
	Air Permeability		Class 4		UNI EN 12207
	Water tightness		Up to E 1500		UNI EN 12208
	Wind load resistance		Up to C5		UNI EN 12210
	Load bearing capacity 350 N		passed		UNI EN 14351-1
	Acoustics (R_w)		44 dB (with glass of 49 dB)		UNI EN 10140-2

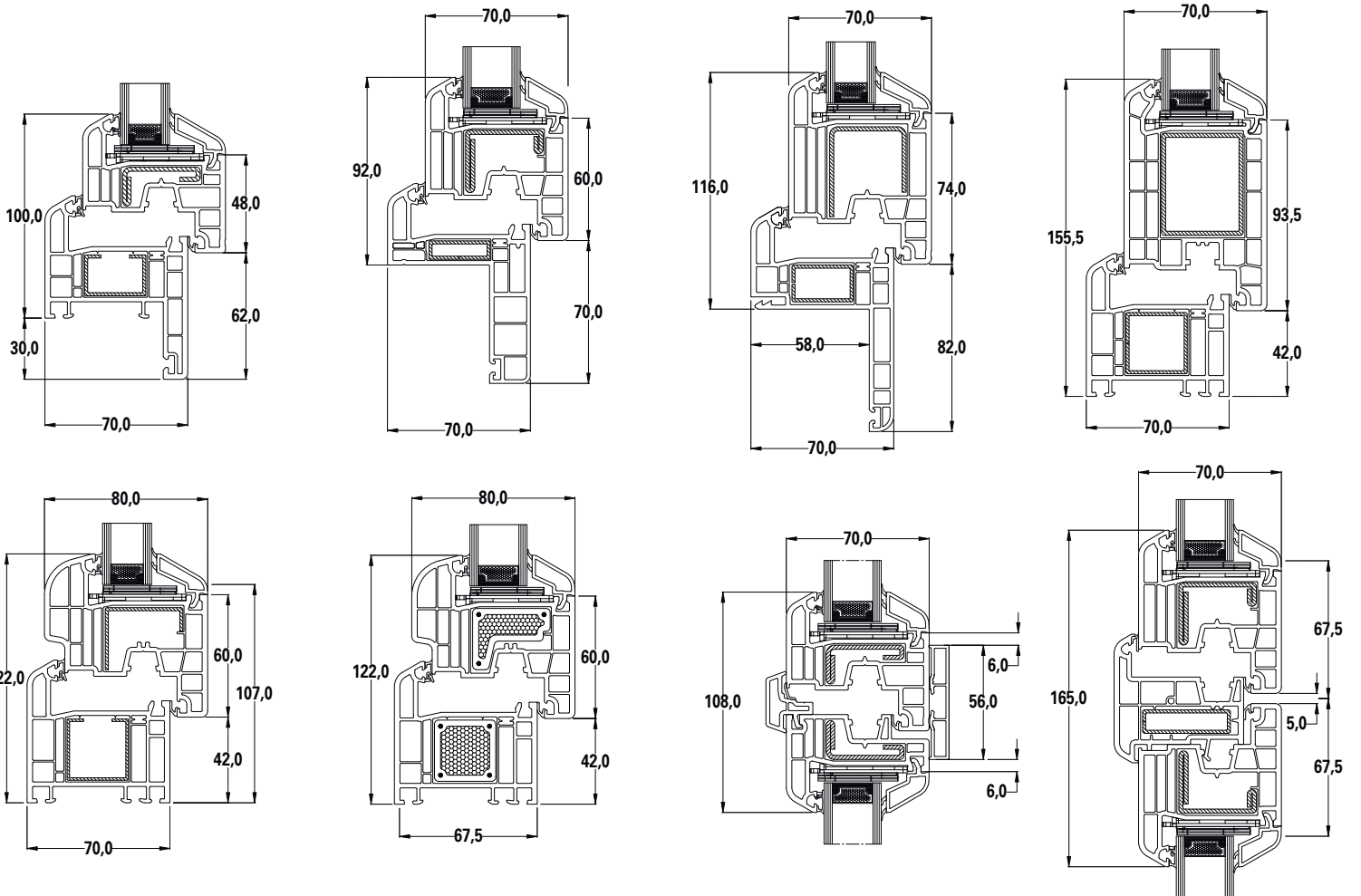

CONSTRUCTION PROPOSALS

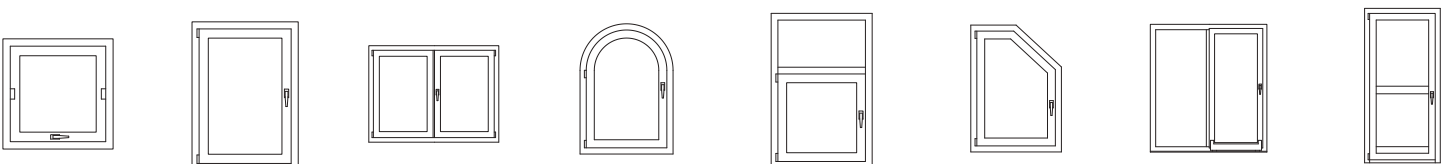



ALPHA EXTREME ALU & IN'ALPHA70 ALU

- Systems with aluminium cladding that can be clipped externally on the profile
- In addition to In'Alpha70 Alu cladding, we designed Alpha Extreme minimal geometry
- New squared glazing bead which follows modern and essential profile lines and its aluminium cladding
- Excellent insulation and acoustic performances even with a slim design of sash and frame
- This solution aims to let you customise the external aesthetics, creating a unique style that perfectly adapts to the architectural and chromatic context of the building
- Paintable in any RAL colour, including metallic effects

IN'ALPHA 70 ALU

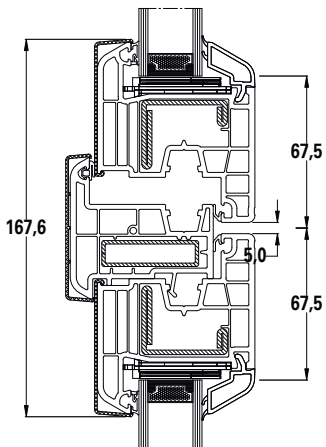
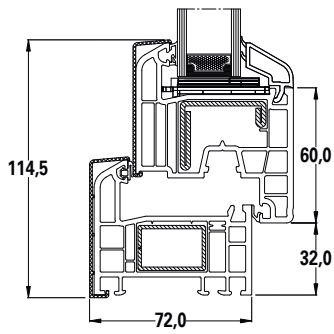

ALPHA EXTREME ALU

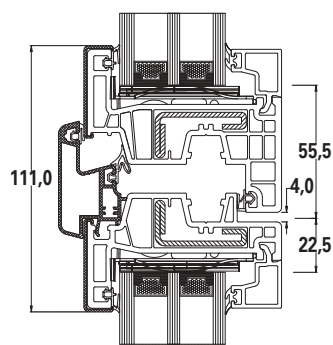
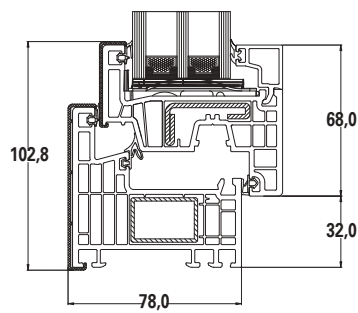

ALPHA EXTREME MODULARE

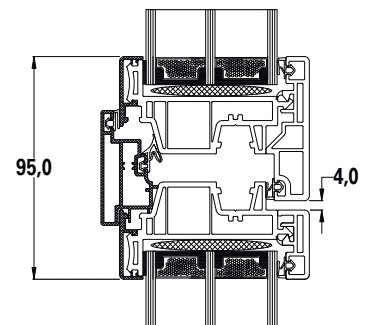
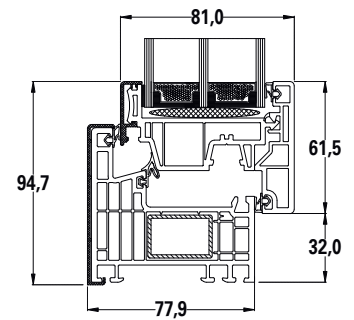

CONSTRUCTION PROPOSALS

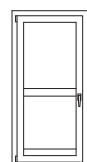
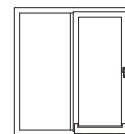
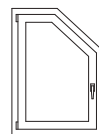
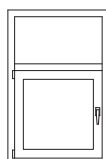
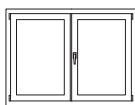

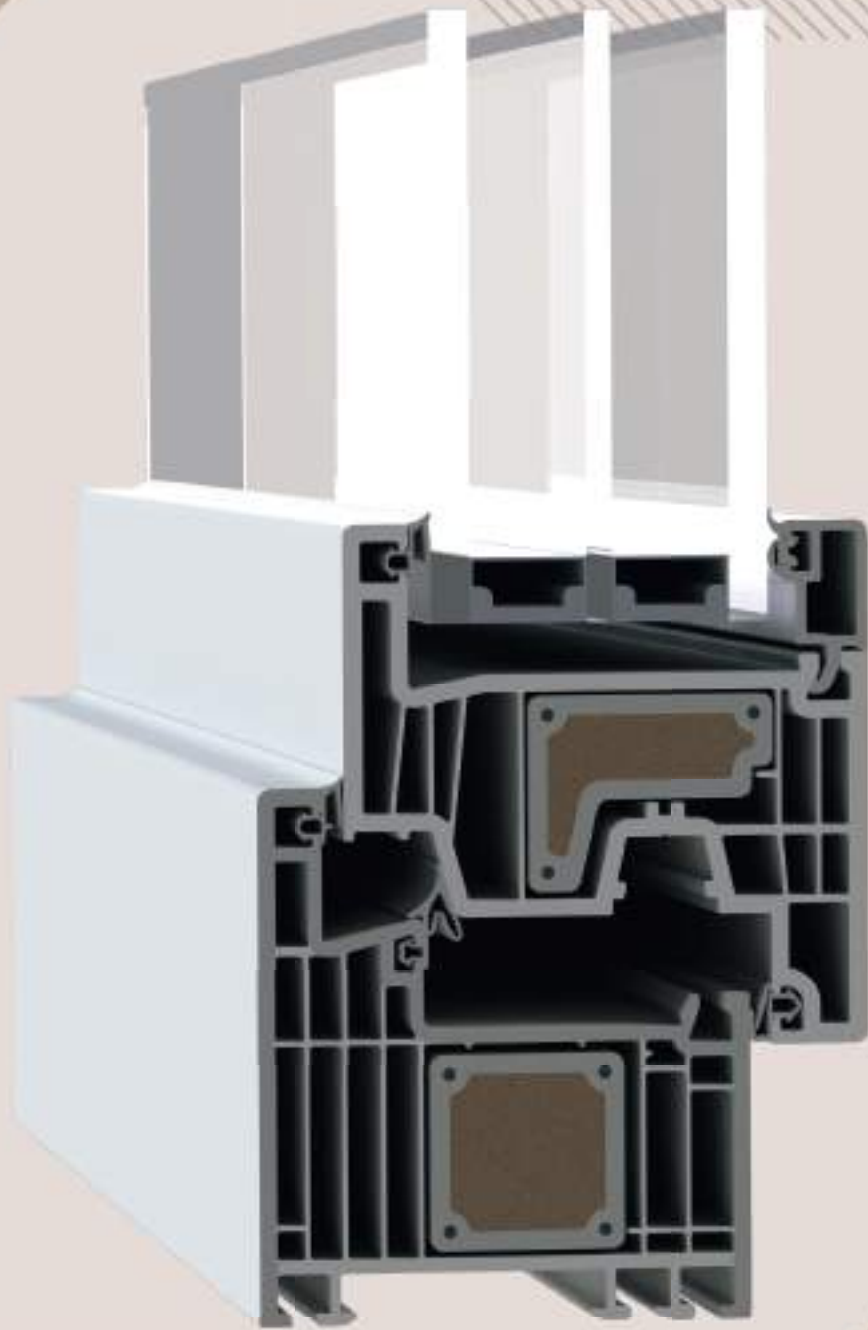

ECO-REINFORCEMENT

Alphacan research allowed the development of profiles for windows and doors equipped – as a premium option – with our synthetic reinforcement. This reinforcement is composed of internal expanded PVC, external frame of rigid PVC and structured longitudinally with fiberglass. This synthetic insulation confers effective mechanical stability properties to the window frame and achieves high thermal and acoustic insulation performances.

Eco-reinforcement is the top model in the range and can be applied to IN'ALPHA70 and ALPHA EXTREME systems.

PERFORMANCE (U_w of the window)

SYSTEM	WINDOW FEATURES	PROPERTIES	VALUE	UNIT	STANDARD
ALPHA EXTREME	1,23 m x 1,48 m $U_g = 0,6 [W/m^2 K]$	Air Permeability	4		UNI EN 12207
		Water tightness	E 900		UNI EN 12208
		Wind load resistance	C3		UNI EN 12210
		Load bearing capacity of safety devices	Passed		UNI EN 14351-1
		Transmittance U_f	0,92	W/m ² K	UNI EN ISO 10077-2
		Transmittance U_w	0,80		UNI EN ISO 10077-1

SYSTEM	WINDOW FEATURES	PROPERTIES	VALUE	UNIT	STANDARD
IN'ALPHA70	1,23 m x 1,48 m $U_g = 0,6 [W/m^2 K]$	Air Permeability	4		UNI EN 12207
		Water tightness	E 900		UNI EN 12208
		Wind load resistance	C3		UNI EN 12210
		Load bearing capacity of safety devices	Passed		UNI EN 14351-1
		Transmittance U_f	1	W/m ² K	UNI EN ISO 10077-2
		Transmittance U_w	0,82		UNI EN ISO 10077-1





SLIDING WINDOWS AND DOORS



HST EXTREME

- Essential, square lines with minimal profiles that allow greater light transmission while maintaining top insulation
- Particularly suitable for large doors
- Designed for large glass surfaces, ideal in residential contexts
- Reinforced sash, excellent structural stability and high resistance to atmospheric agents
- Possibility of a fiberglass flat-step threshold

SYSTEM	PROPERTIES	VALUE	STANDARD
HST EXTREME	Transmittance (U_f) Upper knot fixed part	1,3 W/m ² K	UNI EN ISO 10077-2
	Transmittance (U_f) Upper knot opening part	1,4 W/m ² K	
	Transmittance (U_f) Side knot fixed part	1,3 W/m ² K	
	Transmittance (U_f) Side knot opening part	1,3 W/m ² K	
	Transmittance (U_f) Bottom knot fixed part	1,2 W/m ² K	
	Transmittance (U_f) Bottom knot opening part	1,6 W/m ² K	
	Transmittance (U_f) Central knot	1,6 W/m ² K	
	Air Permeability	4	UNI EN 12207
	Water tightness	7/A	UNI EN 12208
	Wind load resistance	B2	UNI EN 12210

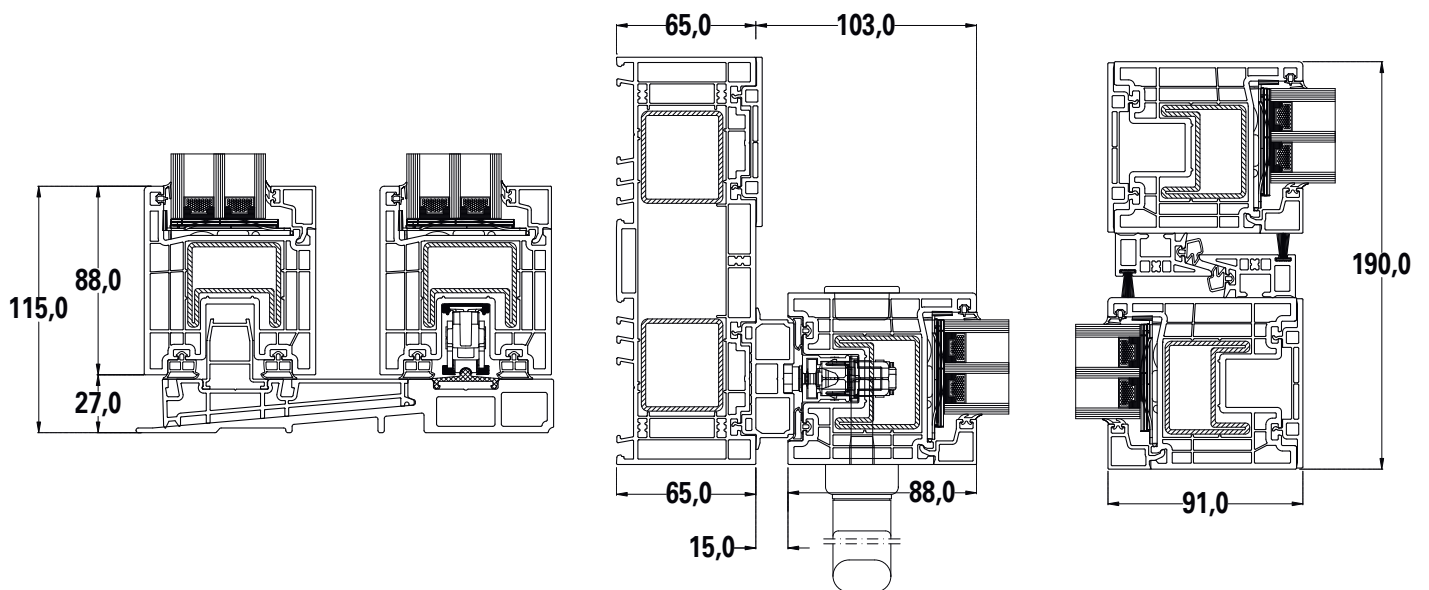

CONSTRUCTION PROPOSALS

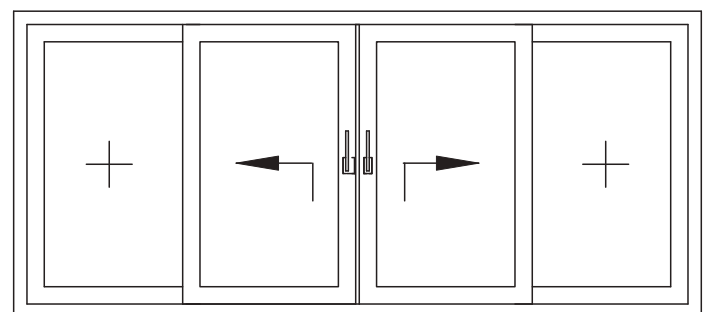
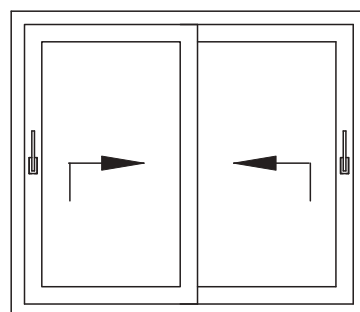
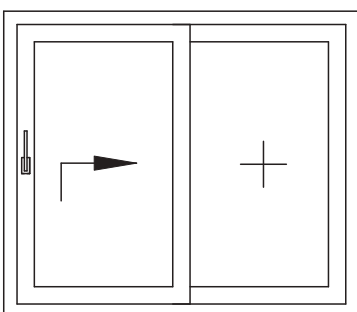



HST EXTREME Minimal

- Suitable for creating large doors and wide windows, perfect for residential contexts. Square lines and slim profiles that let more light into rooms.
- Particularly suitable for large doors
- Designed for large glass surfaces, ideal in residential contexts
- Reinforced sliding sash, great resistance to atmospheric agents
- Possibility of a fiberglass flat-step threshold
- Minimal fixed part, which lets more light in

SYSTEM	PROPERTIES	VALUE	STANDARD
HST EXTREME MINIMAL	Transmittance (U_f) Upper knot fixed part	1,3 W/m ² K	UNI EN ISO 10077-2
	Transmittance (U_f) Upper knot opening part	1,4 W/m ² K	
	Transmittance (U_f) Side knot fixed part	1,3 W/m ² K	
	Transmittance (U_f) Side knot opening part	1,3 W/m ² K	
	Transmittance (U_f) Bottom knot fixed part	1,2 W/m ² K	
	Transmittance (U_f) Bottom knot opening part	1,6 W/m ² K	
	Transmittance (U_f) Central knot	1,6 W/m ² K	
	Air Permeability	4	UNI EN 12207
	Water tightness	7/A	UNI EN 12208
	Wind load resistance	B2	UNI EN 12210

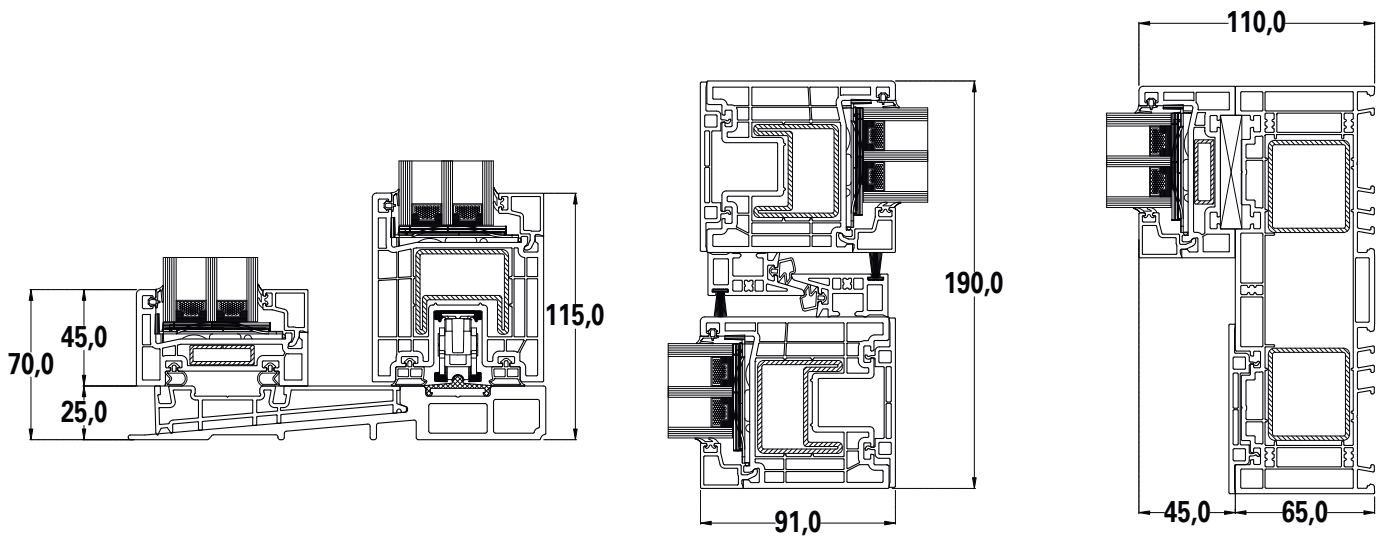

CONSTRUCTION PROPOSALS

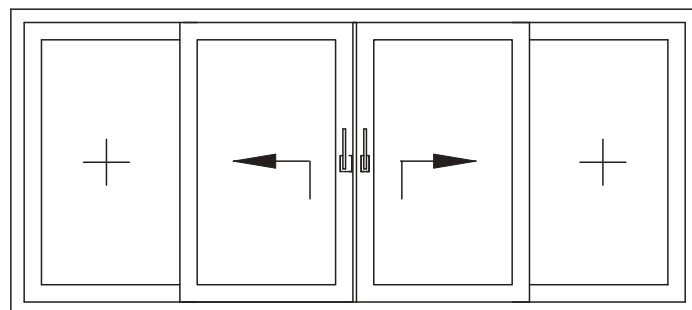
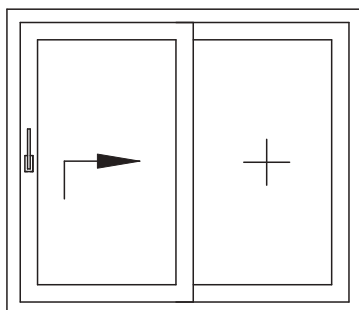



SYSTEM IN'LINE

- Compact, versatile in line sliding system for windows and doors
- It can be equipped with a mosquito net
- Smooth aluminium sliding track and mechanism
- Specific window model with frame geometry suitable for any type of masonry

SYSTEM	PROPERTIES	TEST VALUE
IN'LINE	Transmittance (U_f)	2,3 W/m ² K
	Air Permeability	Class 3
	Water tightness	5A
	Wind load resistance	A2
	Acoustic (R_w)	Chart values according to UNI EN 14351-1

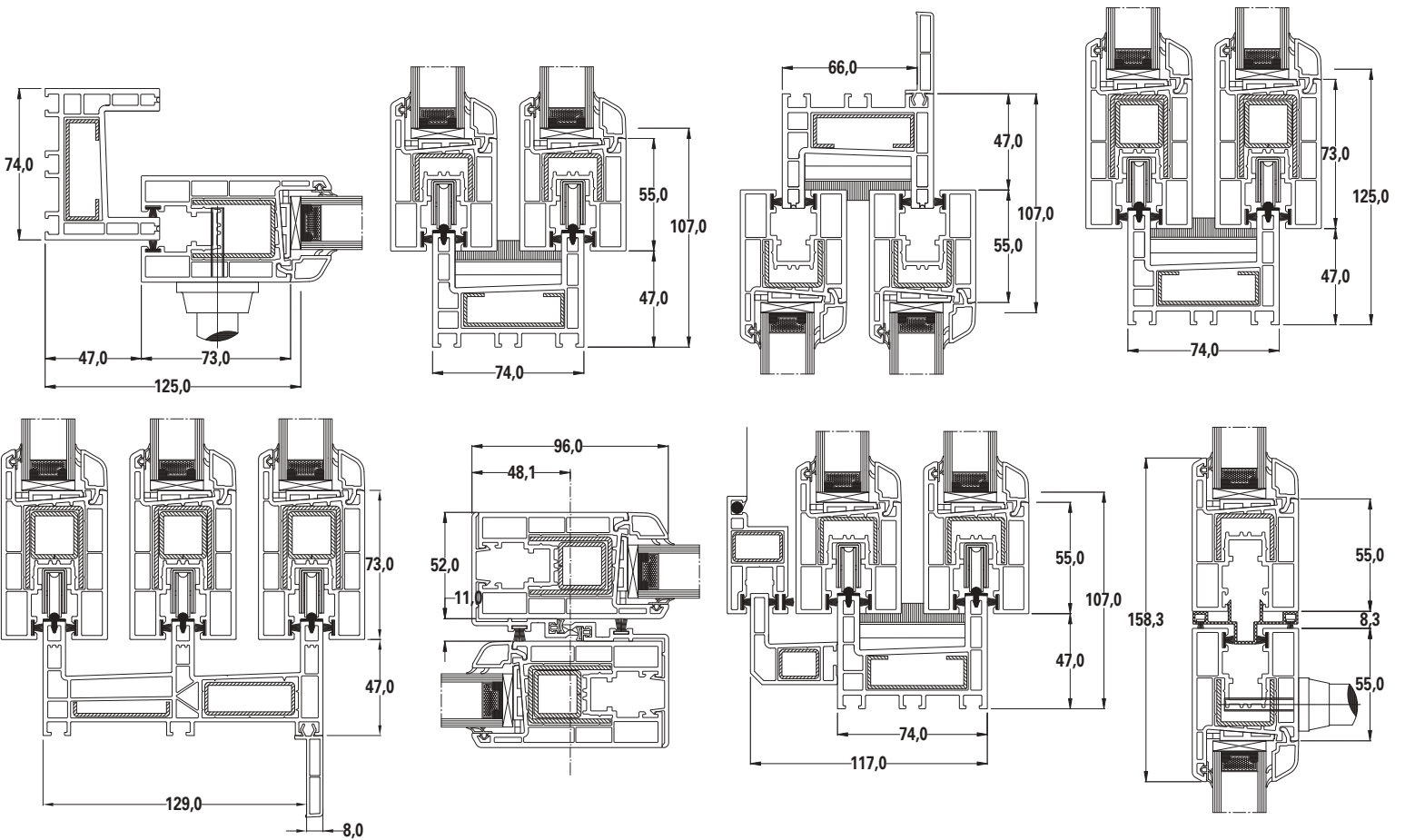

CONSTRUCTION PROPOSALS

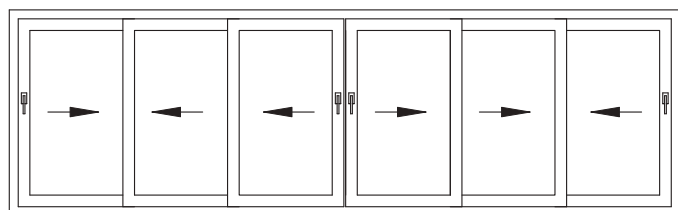
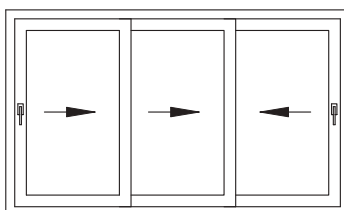
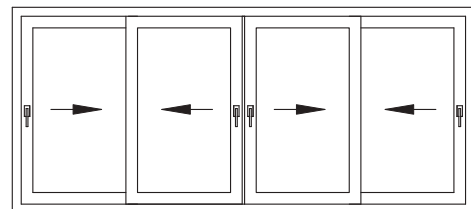
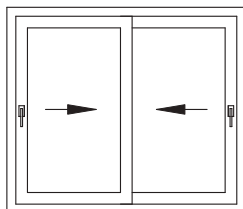
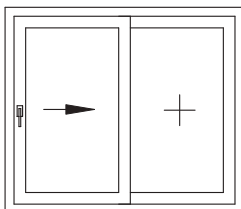



SYSTEM ART SLIDING

- This new sliding system enriches Alphacan product range; windows and doors constructed with its cutting-edge design boast an innovative opening sliding system with optimal stability performances
- Aesthetics, design and attention to detail are always the key points, which make all Alphacan solutions stand out
- Smooth opening and intuitive sliding mechanism
- High resistance to atmospheric agents guaranteed by its its perimetral gaskets and hardware with perimetral closing points

SYSTEM	PROPERTIES	VALUE	STANDARD
ART SLIDING	Transmittance (U_f) Upper knot fixed part	1,24 W/m ² K	UNI EN ISO 10077-2
	Transmittance (U_f) Upper knot opening part	1,33 W/m ² K	
	Transmittance (U_f) Side knot fixed part	1,20 W/m ² K	
	Transmittance (U_f) Side knot opening part	1,37 W/m ² K	
	Transmittance (U_f) Bottom knot fixed part	1,27 W/m ² K	
	Transmittance (U_f) Bottom knot opening part	1,44 W/m ² K	
	Transmittance (U_f) Central knot	2,29 W/m ² K	
	Transmittance (U_f) Central knot with A7270	1,47 W/m ² K	
	Air Permeability	Class 4	
	Water tightness	Class 6A	UNI EN 12208
Wind load resistance	C 2	UNI EN 12210	

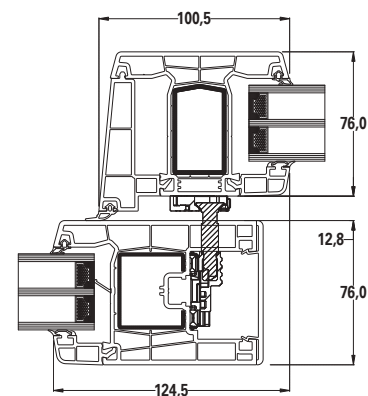
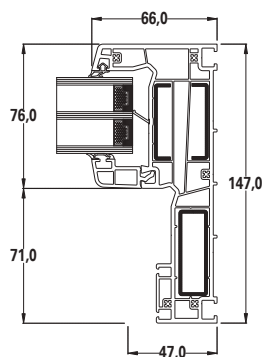
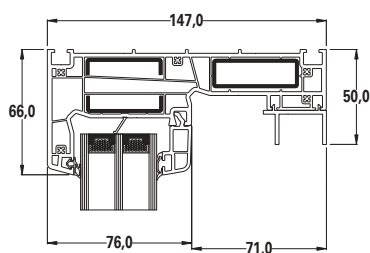
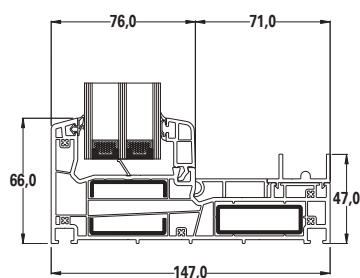
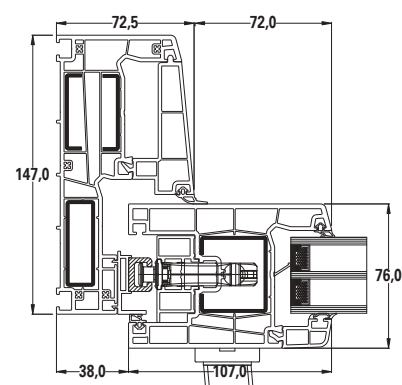
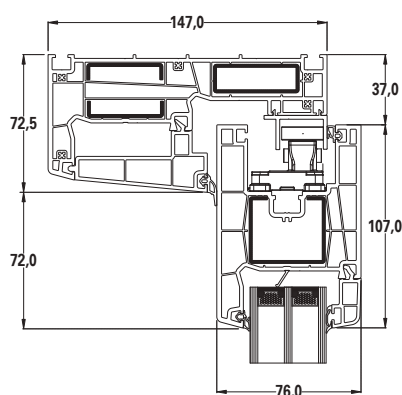
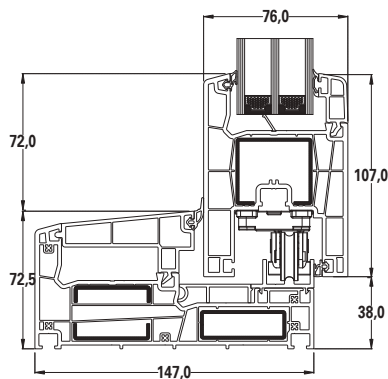

CONSTRUCTION PROPOSALS

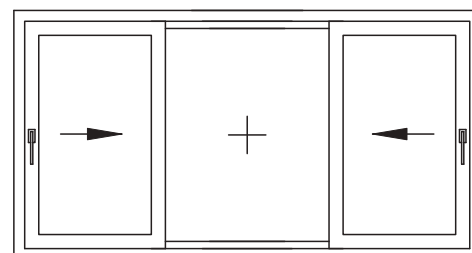
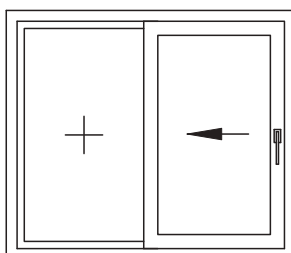
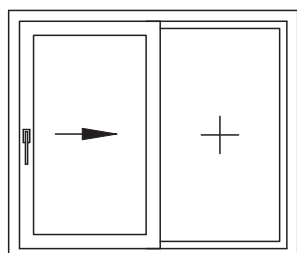





SHUTTER SYSTEMS



PERSIANA - LOUVRE SHUTTER

- Shutter system available with fixed or adjustable louvres
- Versatile design and aesthetics with high resistance to atmospheric agents
- Exclusive technology developed by Alphacan which guarantees optimal results on corner weldings

SYSTEM	PROPERTIES	TEST VALUE
PERSIANA	Wind load resistance	Class 6
PERSIANA	Solar energy transmittance g _{tot}	Class 4

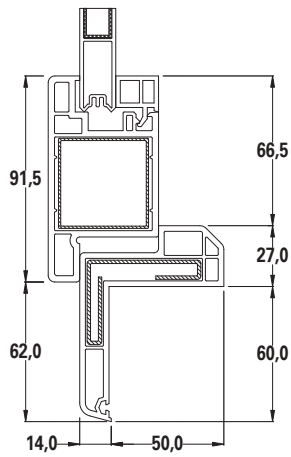
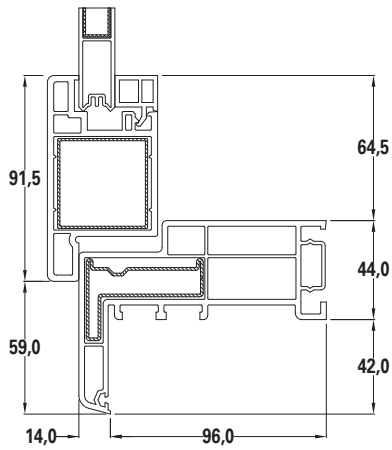
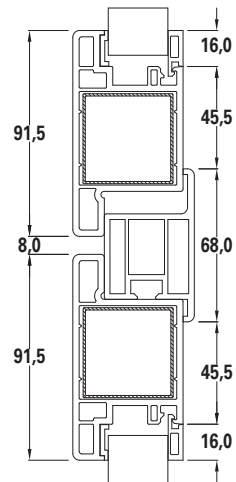
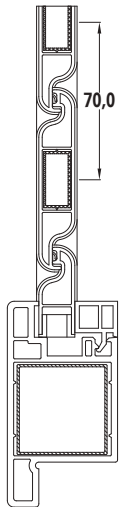

CONSTRUCTION PROPOSALS

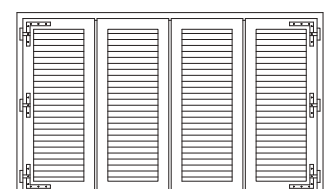
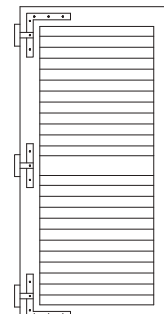
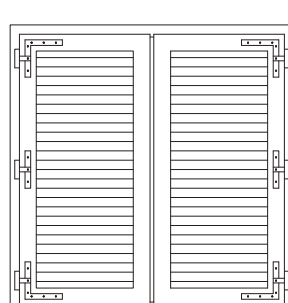
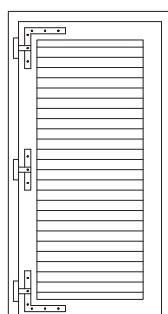
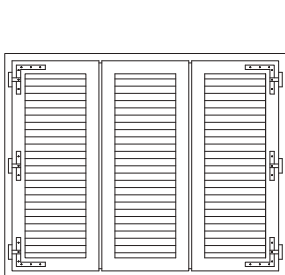

PADOVANA



SCURONE



VICENTINA



SCURO ALLA VENETA

- Characteristic Venetian shutter system, suitable for historical and traditional architectural contexts
- Composed of modular panels vertically joined without intermediate knots
- Equipped with metal reinforcements to confer high stability to the shutter sash
- The bas-relief moulding enhances its appearance with a practical final result

SCURO ALLA VENETA

SYSTEM	PROPERTIES	TEST VALUE
SCURO ALLA VENETA	Wind load resistance	Class 6

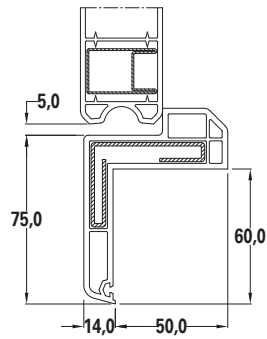
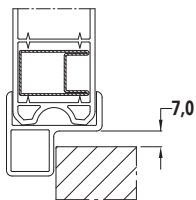
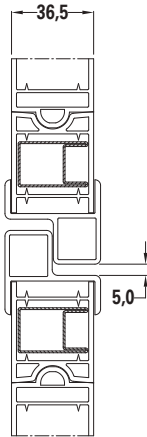
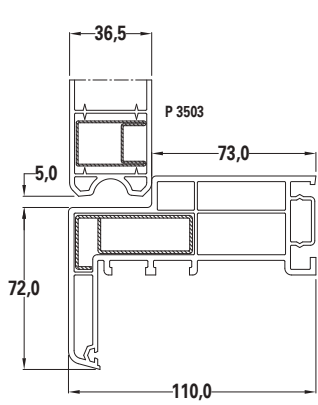

CONSTRUCTION PROPOSALS

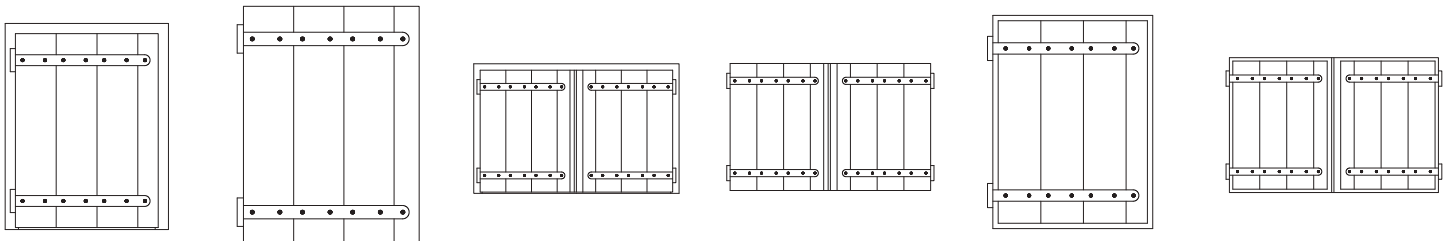



ROLLER SHUTTER BOX LEVANTE

- Single-unit roller shutter box, especially suitable for new constructions
- High thermal-acoustic insulation performances
- Available with different opening mechanisms, also motorised
- Integrated fly net on the inside
- Additional opening on the bottom for box concealed in the wall

ROLLER SHUTTER BOX RENOVATION

- System particularly suitable for renovations
- Suitable to contain large roller shutters, thanks to the particular geometric shape of its components
- Finishings and colours can be matched to the window
- Excellent thermal-acoustic insulation performances

SYSTEM	PROPERTIES	TYPE	TEST VALUE
CASSONETTO LEVANTE	Transmittance (U_{SB})	Standard	0,97 W/m ² K
		With mosquito net	1,3 W/m ² K

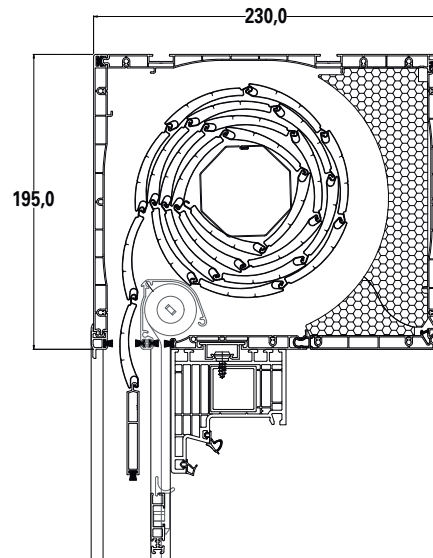
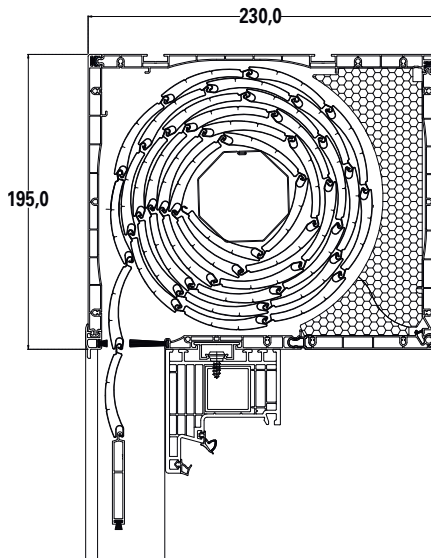

SYSTEM	PROPERTIES	TYPE	TEST VALUE
CASSONETTO RISTRUTTURAZIONE	Transmittance (U_{SB})	Front XPS 24 mm	1,6 W/m ² K
		Front XPS 40 mm	1,4 W/m ² K
		Front XPS 24 mm with side layers EPS 20 mm	1,2 W/m ² K
		Front XPS 40 mm with side layers EPS 20 mm	1,0 W/m ² K

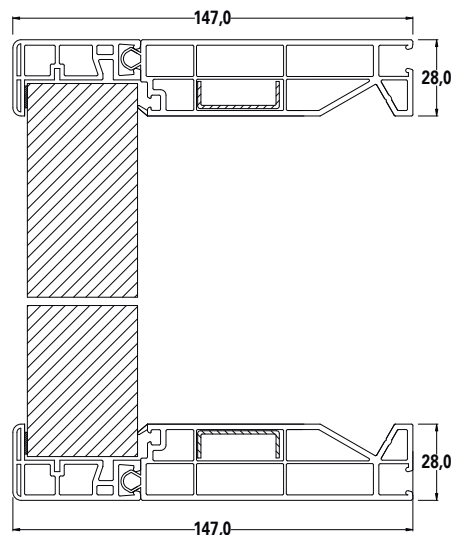
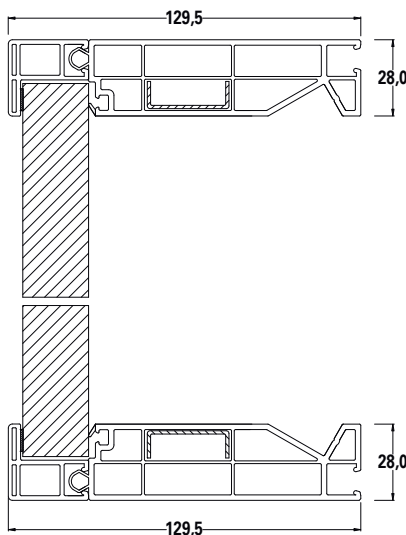

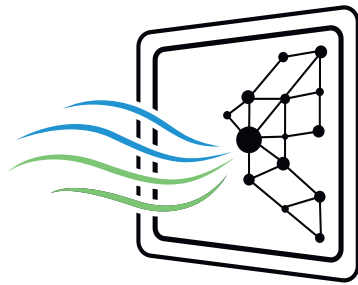

WindQI FOR
ALPHACAN
INNOVATIVE PROFILES & SOLUTIONS

THE SMART EVOLUTION OF THE WINDOW

- Device that can be combined with all windows and motorized sliding systems made with Alphacan PVC profiles
- Perfect combination with roller shutter boxes “Levante” and “Renovation”
- Installation without structural work
- Anti-burglary sensor with built-in alarm
- Built-in sensor that detects air quality, temperature, and humidity
- Available in different colors

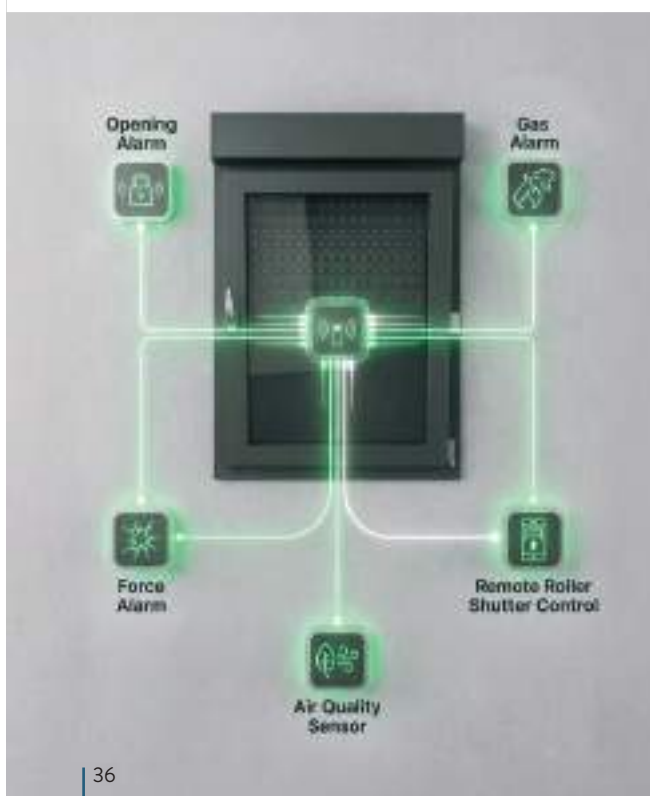

WindQI is a device designed to improve the performance and functionality of a window. It is managed by a user-friendly app that you can use anywhere.

Does not require a central control unit neither radio frequency shutter engines, as the device includes Wi-Fi 6 and Bluetooth connectivity. This results in a much simpler and faster installation process for installers, as well as a significant cost reduction in motorized shutters (approximately 60%).



SHUTTER CONTROL

Real-time, bidirectional control.



SECURITY CONTROL

Integrated window opening and forced-entry alarm.



TEMPERATURE AND AIR QUALITY CONTROL

A sensor detects temperature, humidity and CO2 levels and recommends when to ventilate, increasing the energy efficiency of your home.



FAST INSTALLATION

Developed by experienced window manufacturers, our system requires no machining and can be installed very easily.



WARRANTY

Electronics manufactured in Europe, with a 5-year warranty.



COMPATIBILITY

With the main platforms on the market (Google Home, Amazon Alexa, IFTTT, etc.).





FINISHES AND COLOURS

OUR WINDOW DECORATIONS FOR INTERIOR AND EXTERIOR

The finish LAMINATION represents our commitment to transform windows into unique design and decor elements. With a tailor-made lamination you can choose from an exclusive colour palette, one film for the interior side and another one for the external side.

Your window will be one of a kind!

High resistant to both atmospheric agents and UV-rays, laminated finishes ensure an excellent colour durability over time.

Our palette of available colours includes lamination films ranging from matte, metallic or wooden patterns, to warmer and classic colours, as well as natural and fashionable textures.

Let yourself be inspired.



ARTICO WOODDEC



ATACAMA WOODDEC



SAHARA WOODDEC

A close-up photograph of a window frame. The frame is made of light-colored wood with a vertical grain. A white, multi-layered sealant strip is visible, running vertically along the edge of the frame. The background is slightly blurred, showing an outdoor scene with a paved area and some greenery.

TOTAL COLOR

Alphacan's latest application technology enables the complete decoration of the profile surface.

The complete lamination of the profile results into a great aesthetical final effect giving a sense of harmony, due to the colour uniformity with no contrast between the interior and exterior side of the window.

TAILOR-MADE DECORATIONS FOR INTERIORS



The window you have always dreamed of.

MYDESIGN is a decoration system for the interior profile surface of the window, obtained through an innovative print technology.

Textures, motifs, graphemes or images. You can create your own lamination film and customize your window.

Sash and frame blend with the surrounding environment and play a key role in the interior design.

Window becomes art and enhances the outside landscape.

Beyond maintaining optimal thermal-acoustic performances, MYDESIGN transforms the PVC window's aesthetics. Each window is tailor-made, versatile and unique.

Our colour collection includes textured films, resembling not only natural patterns, but also glamour effects; not to mention the possibility of personalization with logos and abstract graphics for a contemporary style.



LINO VERDE

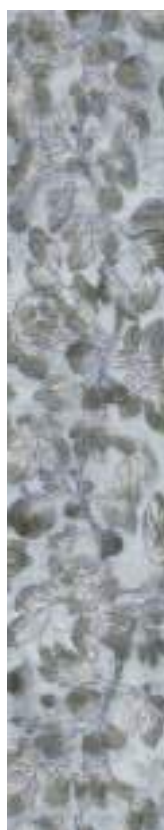

NATURAL DECÒ



TROPICAL PINK



MARMO BIANCO



MARMO BLU



DESERTO ROSSO



COLLECTION NEW PROPOSALS



COLLECTION METALLIC DESIGN



COLLECTION MATT COLOURS



COLLECTION MYDESIGN



COLLECTION CLASSIC COLOURS



MASS COLOURS

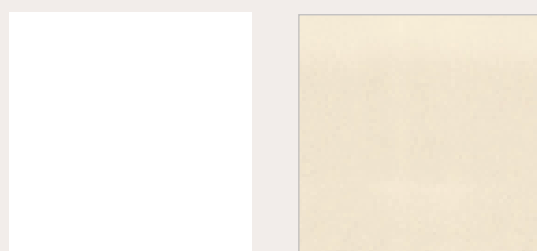

Note: All pictures shown are for illustration purpose only and actual colour may vary from the original





EDITION FEBRUARY 2026

A cura degli Uffici Comunicazione & Marketing, Tecnico Ricerca & Sviluppo.

© Copyright - Tutti i diritti riservati

Any use, copy, reproduction, exploitation, translation, display, in whole or in part of images and texts contained in this volume for any purpose is strictly prohibited, unless prior written consent has been obtained from the Company

Courtesy immagine pagina 8: Progettista d'interni Cristina Baire (Controverso Studio Design) e Serramenti Renato Orrù, Cagliari.

Courtesy immagine copertina e pagina 12, 20: Serramenti Renato Orrù, Cagliari.



ALPHACAN
INNOVATIVE PROFILES & SOLUTIONS

A MEMBER OF



ALPHAPRO

Headquarters and factory
Via San Sisto, 24
I-38062 Arco (TN)

Tel. +39 0464 587 500

info@alphacan.it www.alphacan.com



www.alphacan-mydesign.com